

Attic conversion in Innsbruck AT

PROJECT SUMMARY

An attic conversion of a historic building in Innsbruck built in 1882. The two new levels are built of connected wooden boxes. Complies with Austrian low energy requirements.

SPECIAL FEATURES

- 15 m² solar collectors for DHW
- laminated wooden roof construction
- connected wooden boxes

ARCHITECT

Dipl Ing Daniel Fügenschuh

OWNER

Dr. Michael Harrer
Private



IEA – SHC Task 37

Advanced Housing Renovation with Solar & Conservation

After



BACKGROUND

The massive exterior walls of this five storey 19th century building were not insulated and the original windows were still in place. The attic floor was not used and the roof was in a poor condition. Heating the top apartment needed 193 kWh/(m²a).

After the renovation 2007, including the attic conversion, comfort is greatly improved and the new attic apartments comply with Austrian low energy requirements, needing only 55 kWh/(m²a) for space heating.

OBJECTIVES OF THE RENOVATION

- reduce heating costs
- ecological renovation with renewable resources
- extremely high quality of building and construction
- exceptional interior design

SUMMARY OF THE RENOVATION

- high insulation of facade, floors, roofs
- replacement of old windows
- two connected wooden boxes for new living space
- central gas unit
- solar collectors for preparation of domestic hot water

After

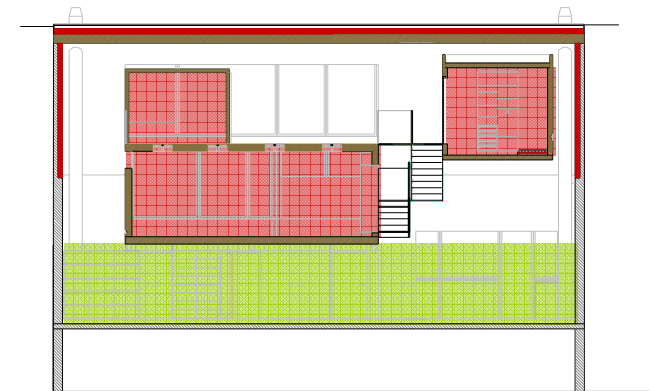

Attic section

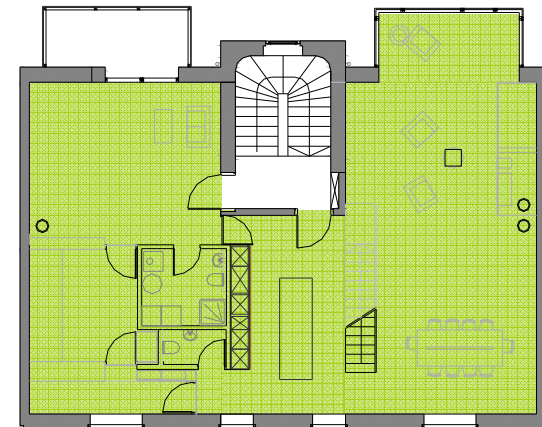

Renovation
Lasting quality

First attic floor

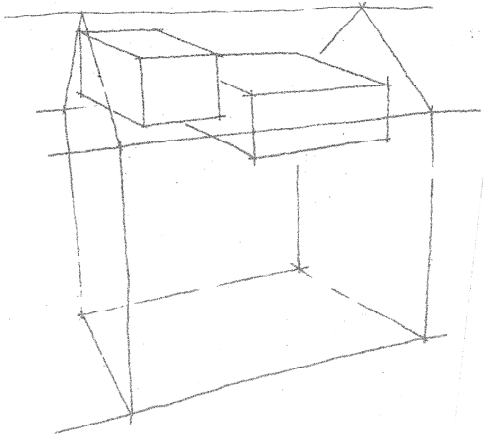

Wood-box system

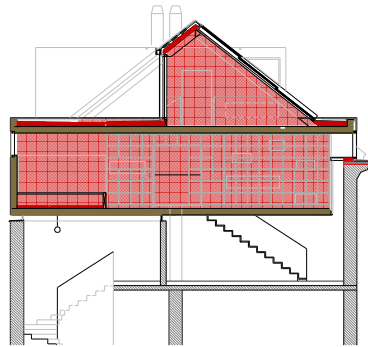

A Section

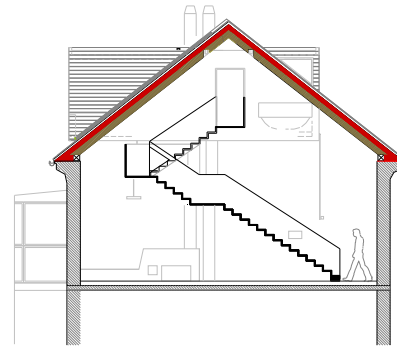

B Section

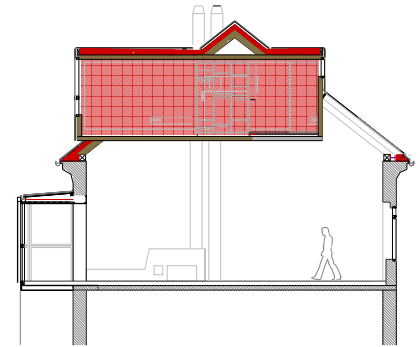

C Section

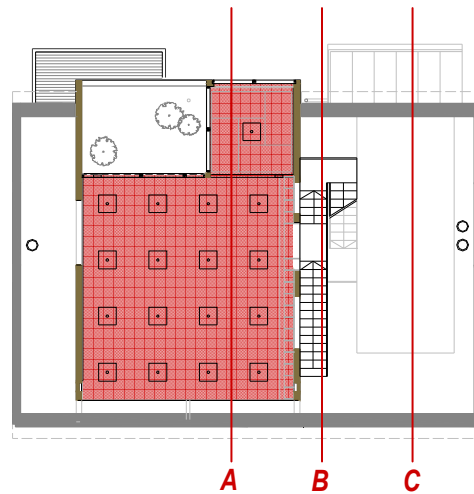

Second attic floor

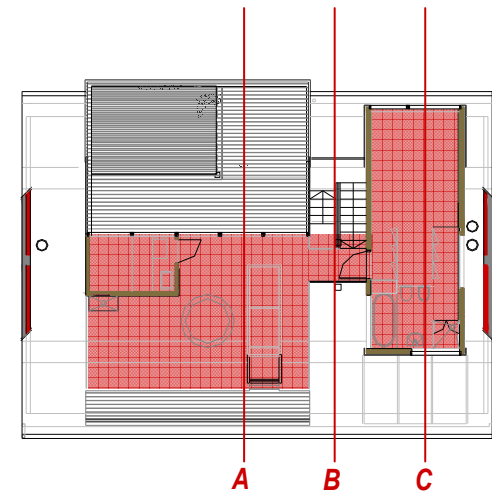

Third attic floor



CONSTRUCTION

Roof construction *U-value: 0.184 W/(m²·K)*
(interior to exterior)

laminated wood	218 mm
wood-fibre insulation	140 mm
air space	
green roof, solar panels, copper	
Total	358 mm

Wall construction *U-value: 0.285 W/(m²·K)*
(interior to exterior)

laminated wood	150 mm
wood-fibre insulation	80 mm
air space	30 mm
boaring	20 mm
Total	280 mm

Seperating ceiling *U-value: 0.864 W/(m²·K)*
(top down)

floor screed	70 mm
impact sound insulation	30 mm
filling	50 mm
concrete floor (existing)	200 mm
Total	350 mm

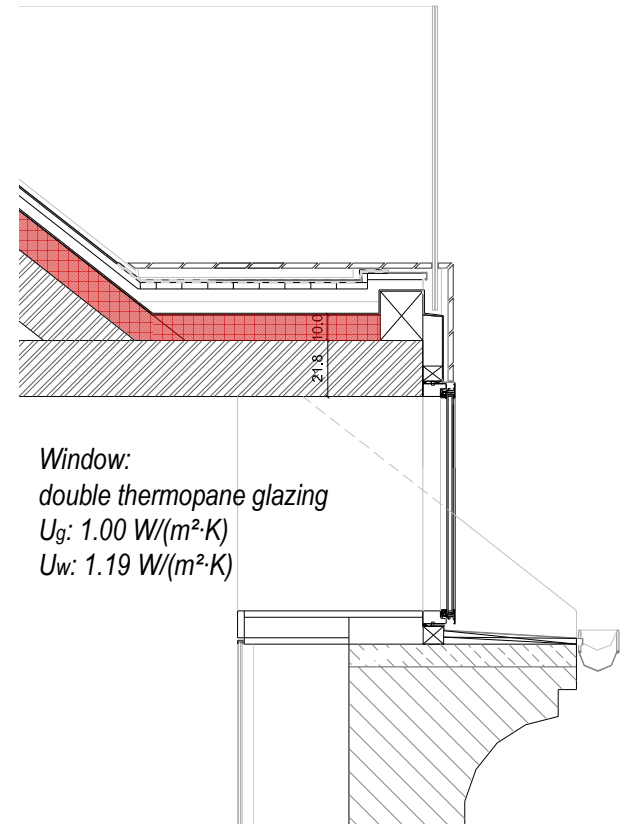

Window section



Summary of U-values $W/(m^2 \cdot K)$

	Before	After
Attic floor	0.8	0.18
Walls	1.1	0.29
Separating ceiling	0.9	0.86
Windows	ca. 2.7	1.19

BUILDING SERVICES

The new floor and wall radiant heating systems are supplied by a new central gas boiler (10 kW). Domestic hot water is heated by solar collectors, back-up is provided by the gas boiler.

RENEWABLE ENERGY USE

15 m² solar collectors on the southeast-oriented roof with only 500 l storage achieve an annual solar fraction of 85% for domestic hot water preparation.

ENERGY PERFORMANCE

Space + water heating (primary energy)*
 Before: 468 kWh/(m²a)
 After: 124 kWh/(m²a)
 Reduction: 74 %

* according to OIB Richtlinie 6

INFORMATION SOURCES

Architekt Daniel Fügenschuh
 Sonnenstraße 7
 A-6020 Innsbruck
www.fuegenschuh.at

Brochure authors

S. Grünewald, S. Rottensteiner

Contact

Thomas Mach
thomas.mach@tugraz.at